

EXPERIMENT 8 MOMENT OF INERTIA

I. THEORY

The purpose of this experiment is to determine the experimental moment of inertia of a disk and of a ring by using the principle of conservation of energy. The experimental moment of inertia will be compared with the theoretical moment of inertia for each.

The theoretical moments of inertia of the bodies used as unknowns in this experiment may be calculated from the following equations:

$$I = \frac{1}{2}MR^2 \text{ for the disk when horizontal.}$$

$$I = \frac{1}{4}MR^2 \text{ for the disk when vertical.}$$

$$I = \frac{1}{2}M(R_1^2 + R_2^2) \text{ for the ring.}$$

A vertical axle supports various bodies whose moment of inertia are to be determined. A small drum is rigidly attached to the axle. A string is wound around the drum and passes over a pulley. A mass, attached to the end of the string, falls to the floor, unwinding the string and accelerating the axle and the experimental body rotationally. We will refer to this as the *driving mass*.

As the driving mass falls to the floor, the gravitational force exerted by the Earth does positive work on the system. This work is equal to the weight of the driving mass times the distance the mass falls.

Friction also does work in this experiment. The work done by friction will be computed by determining what driving mass will fall at a constant speed once set into downward motion. This particular driving mass will be called the *friction mass*. When the driving mass is equal to the friction mass, the kinetic energy of the system does not change. If the kinetic energy does not change, the *total work* done on the system is zero. We will assume that the work done by friction is independent of the driving mass, negative, and equal in magnitude to the weight of the friction mass times the height the driving mass falls.

By the work energy theorem, the total work done on the system will equal the change in kinetic energy of the system. The kinetic energy of our system will be the sum of the *translational* kinetic energy of the driving mass and the *rotational* kinetic energy of the experimental body.

II. LABORATORY PROCEDURE

1. Measure the masses of the disk and ring using the triple beam balance with the 1000-g weight extender.
2. Use a meter stick and a set of caliper jaws to measure the diameter of the disk. Also measure the inner and the outer diameter of the ring. Use the vernier caliper to measure the diameter of the drum which the thread is wrapped around.
3. Place the disk on the axle horizontally. The side of the disk with the indentation for the ring should be up. Mount the pulley to the base and pass the string over it. Make sure that the string is lined up with the pulley and neither the pulley or string rub against any fixed object. Place the apparatus so that the hanging mass (see figure below) can fall to the ground without hitting the lab bench. Place the level on the center of the disk. Adjust the feet of the base of the apparatus until it is level. Remove the level. ***If you move the apparatus after leveling, you will need to repeat the leveling step.***

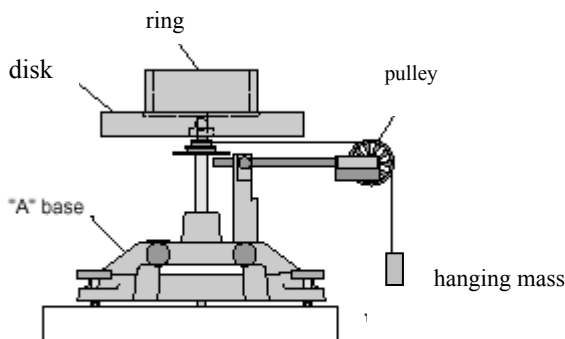

Set-up for Disk and Ring

4. Determine the friction mass to the nearest gram. That is, find by trial and error, the mass which, when attached to the end of the string, keeps the disk and ring rotating at constant speed once started. A slow speed is recommended. If the friction mass exceeds 10 grams, check with the instructor.
5. Remove the friction mass and attach a 50.0 gram driving mass. Wind up the string on the drum and raise the driving mass to a convenient height as measured by a two-meter stick with a caliper jaw. Record the height. Release the mass and start the stopwatch. Stop the watch when the mass strikes the floor. Record the time.
6. Using the same height, carry out two more runs as in step 5.
7. Place the ring on the disk, seating it in the indentation. It is important to center the ring as precisely as possible so that it will be rotating about its center of mass. Determine the friction mass for the disk-ring system.
8. Replace the friction mass by a 100.0 gram driving mass, and carry out three runs as before.

9. Remove the disk and the ring from the axle. Mount the disk vertically by inserting the shaft in one of the two holes on the edge of the disk. The disk should not rotate separate from the axle if the flat side of the axle is against the peg in the hole.
10. Find the friction mass as in step 5.
11. Replace the friction mass by a 50.0 gram driving mass, and carry out three runs as before.

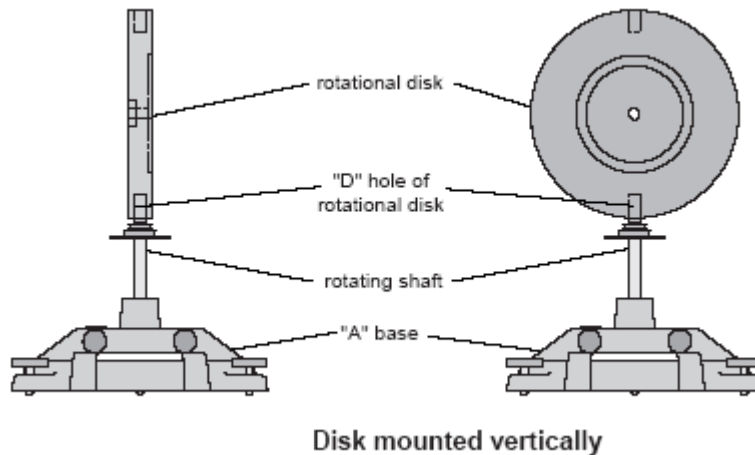

III. CALCULATIONS AND ANALYSIS

Report all of your calculations in SI units. Use scientific notation when appropriate.

Perform calculations 1-4 for the horizontal disk used alone. Show formulas used and all work for this case. Repeat calculations 1-4 for the system of the horizontal disk and ring used together. Repeat for the vertical disk. Present the results in a well labeled and organized table.

1. Assuming that the acceleration of the driving mass was constant, calculate the speed and the translational kinetic energy of the driving mass just as it strikes the ground. Use the average of the three measured times.
2. Using conservation of energy, calculate the rotational kinetic energy of the system just as the driving mass strikes the ground.
3. Calculate the angular velocity of the system just as the driving mass strikes the ground.
4. Using the rotational kinetic energy and the angular velocity of the system, calculate the experimental moment of inertia.

5. Calculate the theoretical moment of inertia of the horizontal disk. Find the percent difference between the experimental and theoretical moment of inertia.
6. By subtracting your experimental results for the horizontal disk and the disk and ring together, find the experimental moment of inertia of the ring alone. Calculate the theoretical moment of inertia of the ring. Find the percent difference between the experimental and theoretical moment of inertia.
7. Calculate the theoretical moment of inertia of the vertical disk. Find the percent difference between the experimental and theoretical moment of inertia.
8. The metal axle on which the disk was mounted is made of aluminum ($\rho = 2.70 \text{ g/cm}^3$) and is approximately 18.2 cm long and 1.2 cm in diameter. Estimate the moment of inertia of the axle. What percent of the total moment of inertia of the system consisting of the axle and the horizontal disk is this? Does ignoring the axle significantly affect the results of the calculated moments of inertia?
9. Explain why, even if the moment of inertia of the metal axle were very large, it would have no effect on your calculation of the experimental value of the moment of inertia of the ring.
10. In your lab report, mention additional sources of error in this experiment, the nature of these errors (systematic or random) and the effects of these errors on the calculation of the moment of inertia of the ring and/or disk. Mention at least one error that specifically affects the calculation of the moment of inertia of the ring. Do the same for the horizontal disk and the vertical disk.